

**FLX™ Self-Regulating
Winterization/Freeze Protection
INSTALLATION PROCEDURES**



The Heat Tracing Specialists®

FLX™ Self-Regulating

Refer to the “FLX Cable Testing Report” for required recording of test data and circuit information.

Upon Receiving Cable . . .

1. Upon receiving heating cable, check to make sure the proper type and output have been received. All cables are printed on the outer jacket with part number, voltage rating and watt output.
2. Visually inspect cable for any damage incurred during shipment. The heating cable should be tested to ensure electrical integrity with at least a 500 Vdc megohmmeter (megger) between the heating cable bus wires and the heating cable metallic braid. IEEE 515.1 recommends that the test voltage for polymer insulated heating cables be 2500 Vdc. Minimum resistance should be 20 megohms. (Record 1 on Cable Testing Report.)

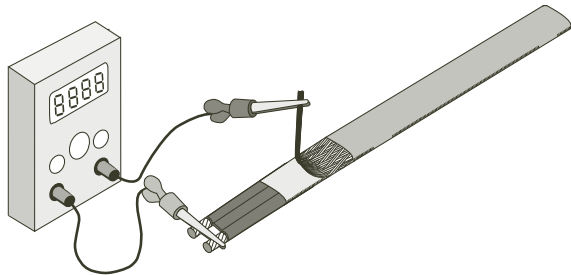

Connect the positive lead of the megger to the cable bus wires and the negative lead to the metallic braid.



CAUTION: DO NOT connect power to heating cable while it is on reel or in shipping carton.

Before Installing Cable . . .

1. Be sure all piping and equipment to be traced is completely installed and pressure tested.
2. Surface areas where heat tracing is to be installed must be reasonably clean. Remove dirt, rust and scale with a wire brush and oil and grease films with a suitable solvent.

INSTALLATION PROCEDURES

Typical Heat Tracing Installation . . .

A complete electric heat tracing system will typically include the following components:

1. Electric heat tracing cable.
2. Power connection kit.
3. Control thermostat (may be remote ambient sensing control.)
4. In-line/T-splice kit (permits two or three cables to be spliced together).
5. Cable end termination.
6. Attachment tape (use on 12” intervals or as required by code or specification).
7. “Electric Heat Tracing” label (peel-and-stick label attaches to insulation vapor barrier on 10’ intervals or as required by code or specification).
8. Thermal insulation and vapor barrier (by others).

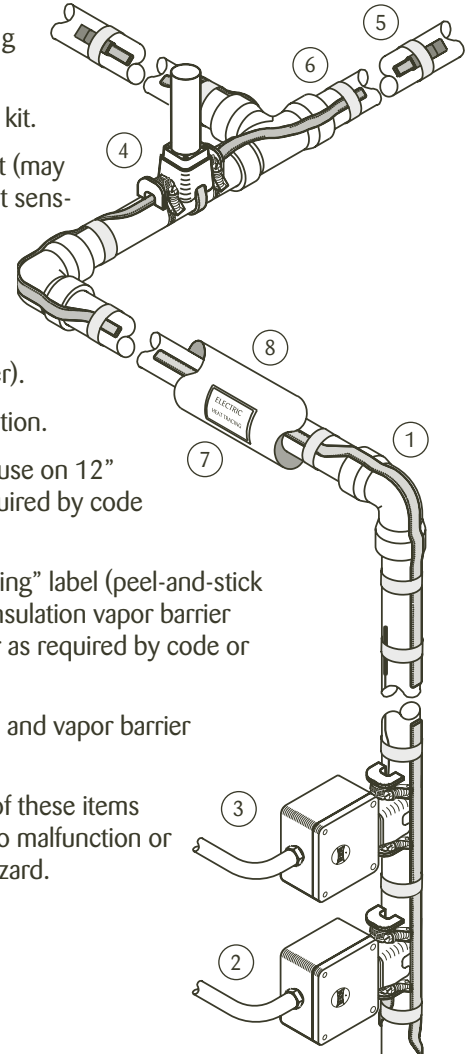

The absence of any of these items can cause a system to malfunction or represent a safety hazard.



The National Electric Code and Canadian Electrical Code require ground-fault protection be provided for all electric heat tracing.



The Heat Tracing Specialists®

FLX™ Self-Regulating

Initial Installation . . .

1. Begin temporary installation at the proposed end-of-circuit location and lay out heating circuit on the pipe, allowing extra cable for the power connection and for any splice locations. Refer to illustration below for temporary installation.
2. Make heating cable allowances for valves, flanges, elbows and supports as per the applicable drawings and table on pages 2 and 3 of these installation procedures. See product specifications sheet for heating cable minimum bend radius.

Temporary Installation

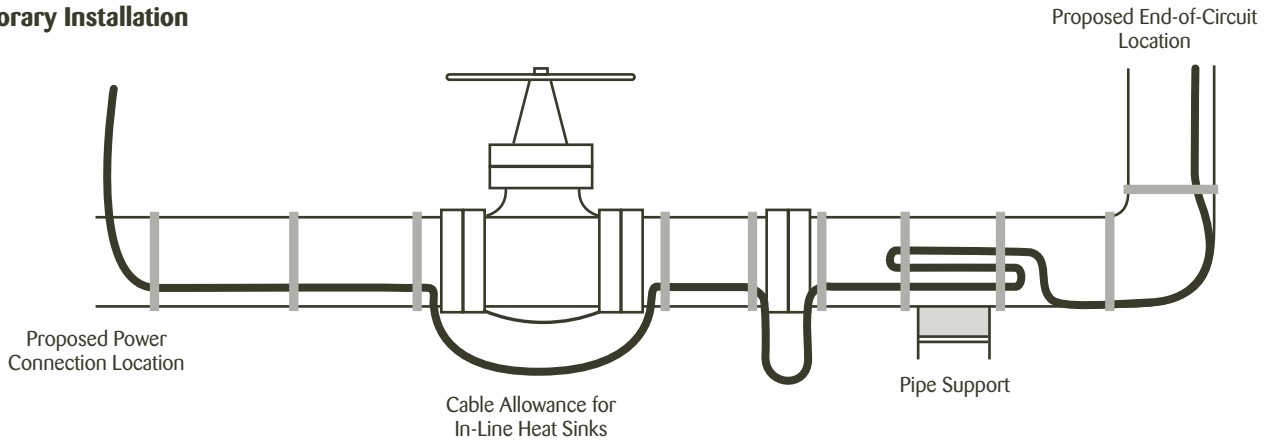

Installation on Fittings and Equipment . . .

1. Install heating cable in accordance with illustrations below. Secure heating cable to piping using attachment tape.
2. Elbows: Locate the cable on the outside radius of an elbow to provide sufficient heat to compensate for the added piping material. Secure the cable to the pipe on each side of the elbow with attachment tape.
3. Pipe Supports: Insulated pipe supports require no additional heating cable. For uninsulated supports, allow two times the length of the pipe support plus an additional 15" (40 cm) of heating cable.

Pipe Elbow

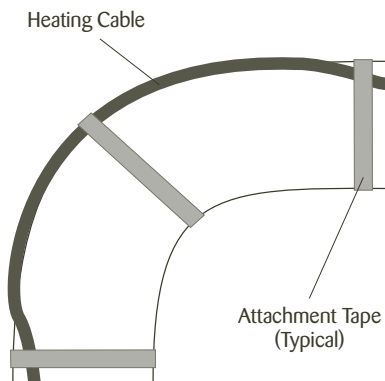

Pipe Support

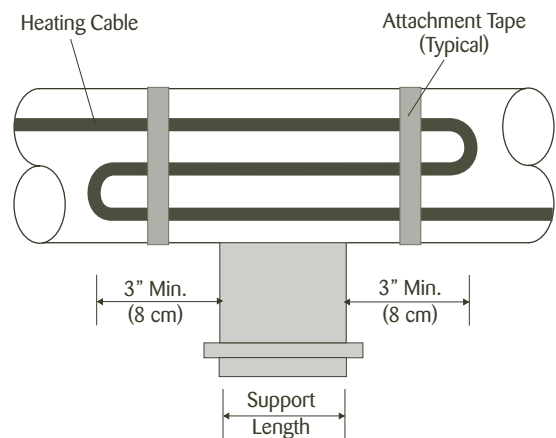

The Heat Tracing Specialists®

INSTALLATION PROCEDURES

4. Flanges: Allow cable to be looped around pipe on each side of and adjacent to the flange. Heating cable must maintain contact with flange when bending around pipe flanges to compensate for additional heat loss.

Typical Flange Detail

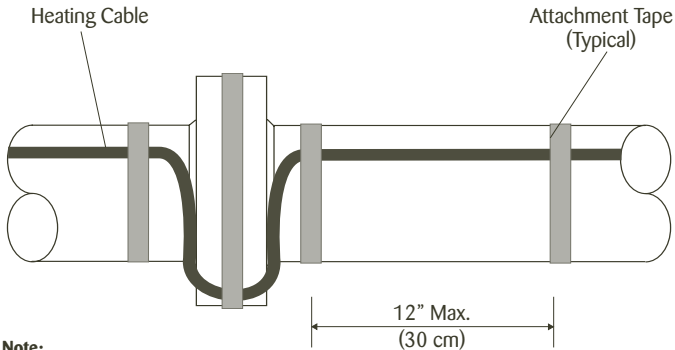

Note: Flange allowance will vary based on method of insulating flange and adjacent piping.

6. Install heating cable on valves and pumps utilizing a looping technique (this allows the valve or pump to be removed if required).

Typical Valve Details

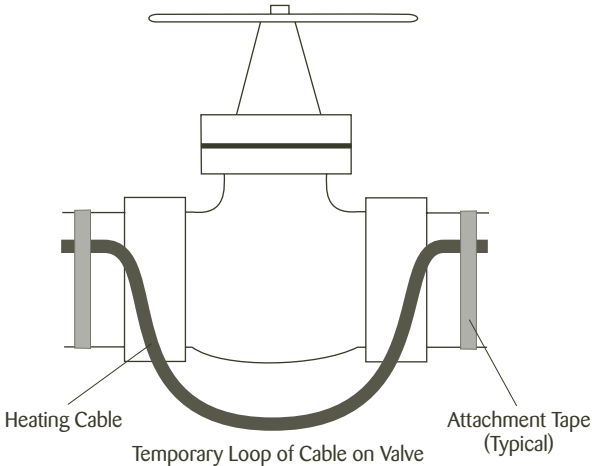

5. Additional cable is required to provide extra heat at valves, pumps and miscellaneous equipment to offset the increased heat loss associated with these items. Refer to Table 1 for estimated cable requirements for installation on typical valves and pumps.

Table 1: Valve and Pump Allowances

Pipe Size	Valve Type			Pump Type	
	Screwed	Flanged	Welded	Screwed	Flanged
1/2"	6"	1'	0	1'	2'
3/4"	9"	1'-6"	0	1'-6"	3'
1"	1'	2'	1'	2'	4'
1 1/4"	1'-6"	2'	1'	3'	4'-6"
1 1/2"	1'-6"	2'-6"	1'-6"	3'	5'
2"	2'	2'-6"	2'	4'	5'-6"
3"	2'-6"	3'-6"	2'-6"	5'	7'
4"	4'	5'	3'	8'	10'
6"	7'	8'	3'-6"	14'	16'
8"	9'-6"	11'	4'	19'	22'
10"	12'-6"	14'	4'	25'	28'
12"	15'	16'-6"	5'	30'	33'
14"	18'	19'-6"	5'-6"	36'	39'
16"	21'-6"	23'	6'	43'	46'
18"	25'-6"	27'	6'-6"	51'	54'
20"	28'-6"	30'	7'	57'	60'
24"	34'	36'	8'	68'	72'
30"	40'	42'	10'	80'	84'

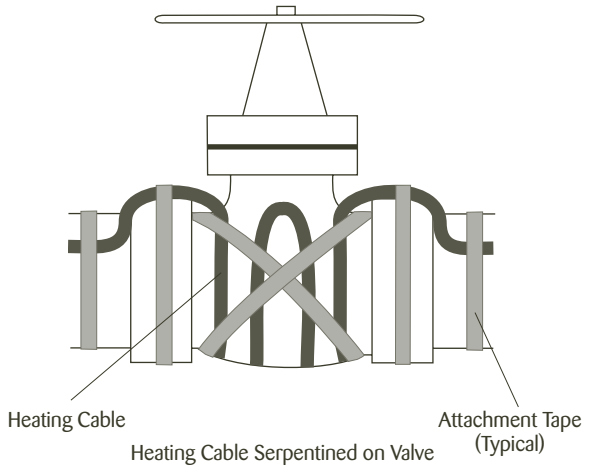

Typical Pump Detail

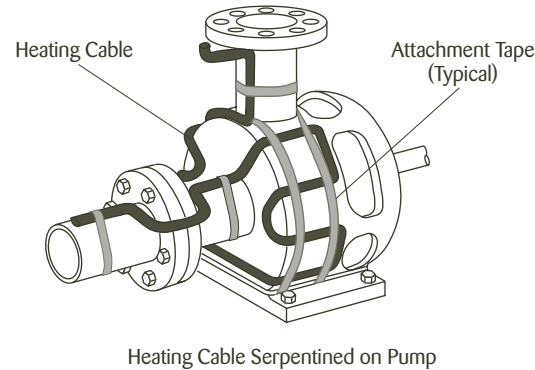

FLX™ Self-Regulating

Completing the Installation . . .

- Begin final cable attachment by securing the end-of-circuit termination kit and working back toward the power supply.
 - Flexible heating cables are to be installed using attachment tape. Circumferential bands of tape should be installed at 12" (30 cm) intervals to keep the cable in proper contact with the pipe. Refer to Table 2 below to calculate the number of rolls of attachment tape required based on the pipe diameter¹.
 - If applicable, refer to installation details provided with the project drawings or contact Thermon for additional information regarding installation.
- In addition to the circumferential tape requirements, a continuous covering of aluminum foil tape may be required when:
 - Spray or foam urethane² thermal insulation is applied.
 - Heat tracing nonmetallic piping.
 - Design requirements dictate the use of aluminum tape to improve heat transfer.
- Complete splice connections (if required) in accordance with the installation instructions provided with the splice kit.
- Install power connection kit in accordance to the detailed installation instructions provided with the kit.
- Before making power connections, repeat the megger test with at least a 500 Vdc megohmmeter (megger) between the heating cable bus wires and the heating cable metallic braid. IEEE 515.1 recommends that the test voltage for polymer insulated heating cables be 2500 Vdc. The minimum acceptable level for the megger reading for any polymer-insulated heat tracing cable is 20 megohms. (Record 2 on Cable Testing Report)

Notes . . .

- Table 2 assumes circumferential bands every 12" (30 cm) along the length of the piping.
- Verify exposure temperature of heating cable versus curing temperature of insulation.

Temperature Control . . .

- When a line sensing controller is specified, the sensor should be placed at least 90° around the circumference from the heating cable, or at least 2" (5 cm) from the cable.

Heating Cable vs. Sensor Location

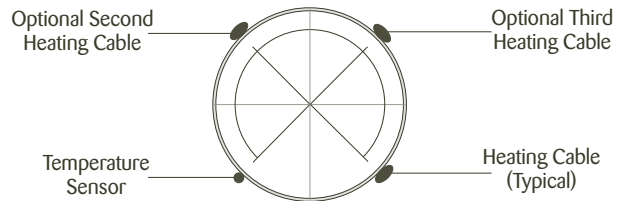

- For pipewall sensing thermostatic control, the heating circuit is to be connected in series with the control contacts as shown in illustration below. The pipewall sensing thermostat may require more than one support point.

Pipewall Sensing Control Connection

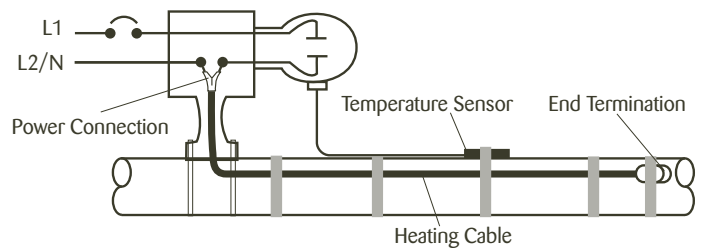

- When using an ambient sensing temperature controller, the mounting location should be representative of the coldest region, and the sensing element should not be exposed to direct sunlight or any additional heat source.

Ambient Sensing Control Connection

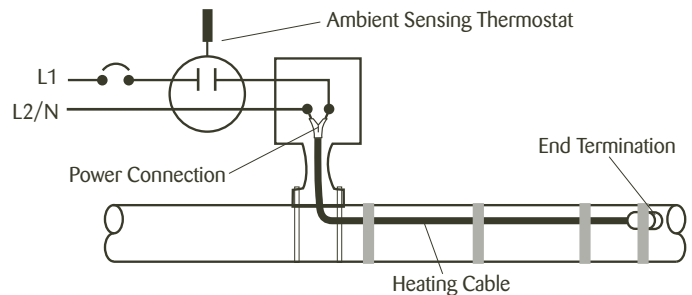

Table 2: Attachment Tape (Value Represents Approximate Linear Pipe Length Allowance Per Roll)

Tape Length	Pipe Diameter in Inches															
	½"-1"	1¼"	1½"	2"	3"	4"	6"	8"	10"	12"	14"	16"	18"	20"	24"	30"
36 yd	130'	115'	110'	95'	75'	65'	50'	40'	35'	30'	26'	23'	21'	19'	16'	13'
60 yd	215'	195'	180'	160'	125'	105'	80'	65'	55'	50'	43'	38'	35'	31'	27'	22'



The Heat Tracing Specialists®

INSTALLATION PROCEDURES

Thermal Insulation . . .

1. The need for properly installed and well-maintained thermal insulation cannot be overemphasized. Without insulation, heat losses are generally too high to be offset by a conventional heat tracing system.
2. In addition to piping and in-line equipment such as pumps and valves, all heat sinks must be properly insulated. This includes pipe supports, hangers, flanges and, in most cases, valve bonnets.
3. Regardless of the type or thickness of insulation used, a protective barrier should be installed. This protects the insulation from moisture intrusion, physical damage and helps ensure the proper performance of the heat tracing system. Seal around all penetrations through the thermal insulation.
4. After the installation of the thermal insulation and weather barrier but BEFORE ENERGIZING THE HEATING CIRCUIT, the megohmmeter test should be repeated. This should call attention to any damage to the heating cable that may have occurred during the insulation installation. (Record 3 on Cable Testing Report)
5. Apply caution labels to insulation weather barrier at required intervals along pipe

Final Inspection and Documentation . . .

1. It is recommended that the circuit be temporarily energized so that the volts, amps, pipe temperature and ambient temperature may be recorded. This information may be of value for future reference and should be maintained for the historical operating data log (Record 4 on Cable Testing Report).
2. Once power is connected but before putting the system into operation, verify all heating cable testing and documentation have been completed for each heat tracing circuit. This will ensure that the system has been installed per the manufacturers recommendations.



The National Electric Code and Canadian Electrical Code require ground-fault protection be provided for branch circuits supplying electric heat tracing on fixed outdoor electric de-icing and snow-melting equipment.

Thermal Insulation with Weather Barrier

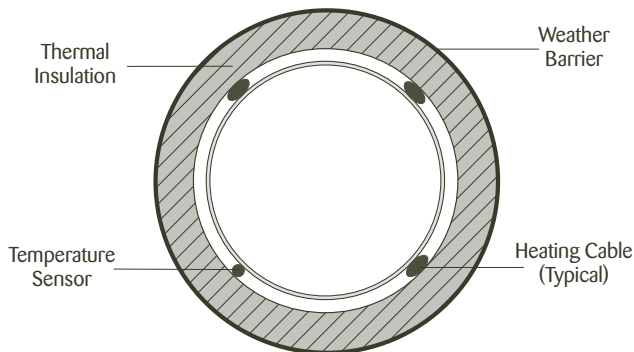

FLX™ Self-Regulating

Installation Guidelines for Fire Protection Systems

1. Where above ground water-filled supply pipes, risers, system risers or feed mains pass through open areas, cold rooms, passageways, or other areas exposed to freezing temperatures, the pipe shall be protected against freezing in accordance with NFPA 13, "Standard for the Installation of Sprinkler Systems".
2. Thermon's FLX Self-Regulating Heating Cables are UL Listed for use on Fire Protection System Piping. This approval states these cables may be used on insulated standpipe and sprinkler system pipe up to and including 6" (15 cm) size, including use on elbows, tees, flanges, hangers and valves, where the minimum ambient temperature is not less than -40°F (-40°C). This application approval includes piping which connects between buildings in unheated areas, piping located in unheated areas or piping through coolers or freezers. As with all heat traced piping systems, thermal insulation is required to ensure the heating system can compensate for heat losses.
3. NFPA 13 states, "it is an unacceptable practice to heat trace and insulate branch lines" of fire protection piping. However, heat tracing and insulation are acceptable means of protecting feed mains, risers and cross mains.
4. In accordance with IEEE 515.1 guidelines, the use of ambient sensing control with low temperature and continuity monitoring as a minimum for all fire protection piping heat tracing systems is required; Thermon recommends the use of an electronic controller with RTD sensing be considered for these applications.

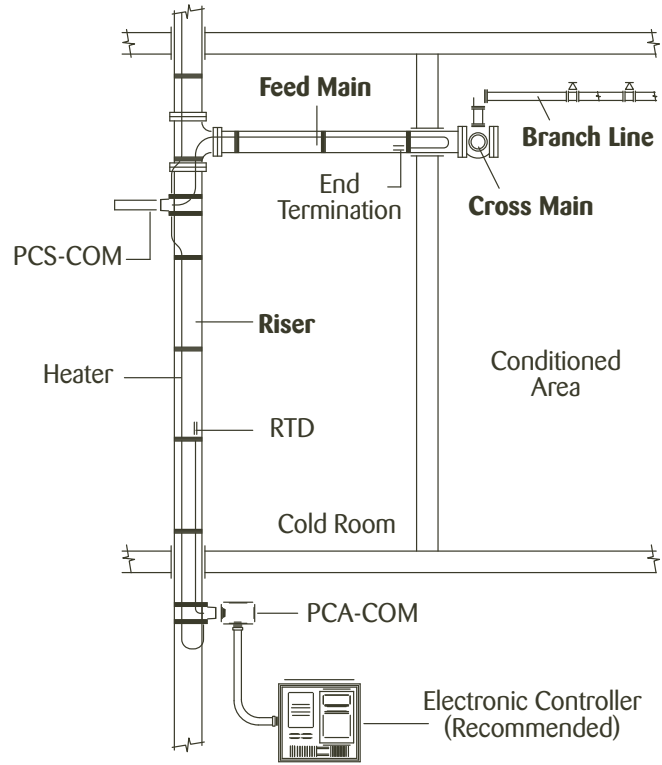

THE NFPA DEFINES THE FOLLOWING:

Branch Lines—The pipes in which the sprinklers are placed, either directly or through risers.

Cross Mains—The pipes supplying the branch lines, either directly or through risers.

Feed Mains—The pipes supplying cross mains, either directly or through risers.

Risers—The vertical supply pipes in a sprinkler system.



The Heat Tracing Specialists®

FLX™ Cable Testing Report

1. Refer to Thermon FLX Installation Procedures, FORM CPD0000, for general installation procedures, requirements and guidelines.

2. Upon receiving heating cable, check the cable to make sure the proper type and output have been received. All cables are printed on the outer jacket with part number, voltage rating and watt output.

3. Visually inspect cable for any damage incurred during shipment.

The heating cable should be tested to ensure electrical integrity with at least a 500 Vdc megohmmeter (megger) between the heating cable bus wires and the heating cable metallic braid.

IEEE 515.1 recommends that the test voltage for polymer insulated heating cables be 2500 Vdc. Minimum resistance should be 20 megohms. **(Record 1 on Cable Testing Report.)**

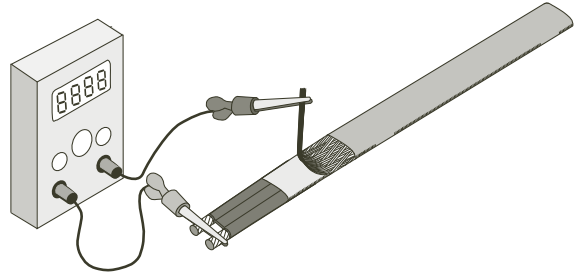

A. Connect the positive lead of the megger to the cable bus wires.

B. Connect the negative lead of the megger to the metallic braid.

C. Energize the megger and record the reading. Readings between 20 megohms and infinity are acceptable. Readings below 20 megohms may mean the electrical insulation has been damaged. Recheck the heating cable for physical damage between the braid and the heating element; small cuts or scuffmarks on the outer jacket will not affect the megger reading unless there was actual penetration through the braid and dielectric insulation jacket.

4. Once the installation is complete, but prior to installation of thermal insulation, recheck the heating cable with at least a 500 Vdc megohmmeter (megger) between the heating cable bus wires and the heating cable metallic braid. IEEE 515.1 recommends that the test voltage for polymer insulated heating cables be 2500 Vdc. Minimum resistance should be 20 megohms. **(Record 2 on Cable Testing Report.)**

5. After the thermal insulation is installed, the megohmmeter test should be repeated. Minimum resistance should be 20 megohms. **(Record 3 on Cable Testing Report.)**

6. After the thermal insulation is installed and power supply is completed, record the panel and circuit breaker information. Ensure all junction boxes, temperature controllers, cable glands, etc. are properly secured. Set the temperature controller (if applicable) to the manual setting and apply rated voltage to the heat tracing circuit(s) for 10 minutes. Record the ambient temperature, measure and record the circuit(s) voltage and current. **(Record 4 on Cable Testing Report.)**

NOTE: To ensure the heating cable warranty is maintained through installation, the testing outlined on this sheet must be completed on the installed heating cables, and the test results recorded and mailed/faxed to:

Thermon Customer Service
100 Thermon Drive
San Marcos, Texas 78666
Fax: 512-754-2420

FLX™ Cable Testing Report

Customer: _____

Contractor: _____

Address: _____

Address: _____

Phone No: _____

Phone No. _____

Project Reference: _____

Record 1: Prior to Installation

Cable Type: _____

Heater Length: _____

Heater Number: _____

Insulation Resistance M Ohms: _____

Tested By: _____

Date: _____

Witnessed By: _____

Date: _____

Record 2: After Installation

Insulation Resistance M Ohms: _____

Tested By: _____

Date: _____

Witnessed By: _____

Date: _____

Record 3: While Pouring Concrete

Insulation Resistance M Ohms: _____

Tested By: _____

Date: _____

Witnessed By: _____

Date: _____

Record 4: Final Commissioning

Panel Number: _____

Breaker Number: _____

Volts: _____

Ambient Temperature (deg. F): _____

Recorded Amps: _____

Tested By: _____

Date: _____

Witnessed By: _____

Date: _____

Other Products . . .

Thermon offers additional cut-to-length cables or complete turn-key systems for the following applications:

- Hot Water Temperature Maintenance
- Freezer Floor Frost Heave Prevention
- Rail and Rail Switch Heating
- Tank and Hopper Heating
- Instrument Heating Systems
- Control and Monitoring Systems



ISO 9001
REGISTERED